

**HOME SOURCE®**

**ASSEMBLY INSTRUCTION**

MODEL: DC116

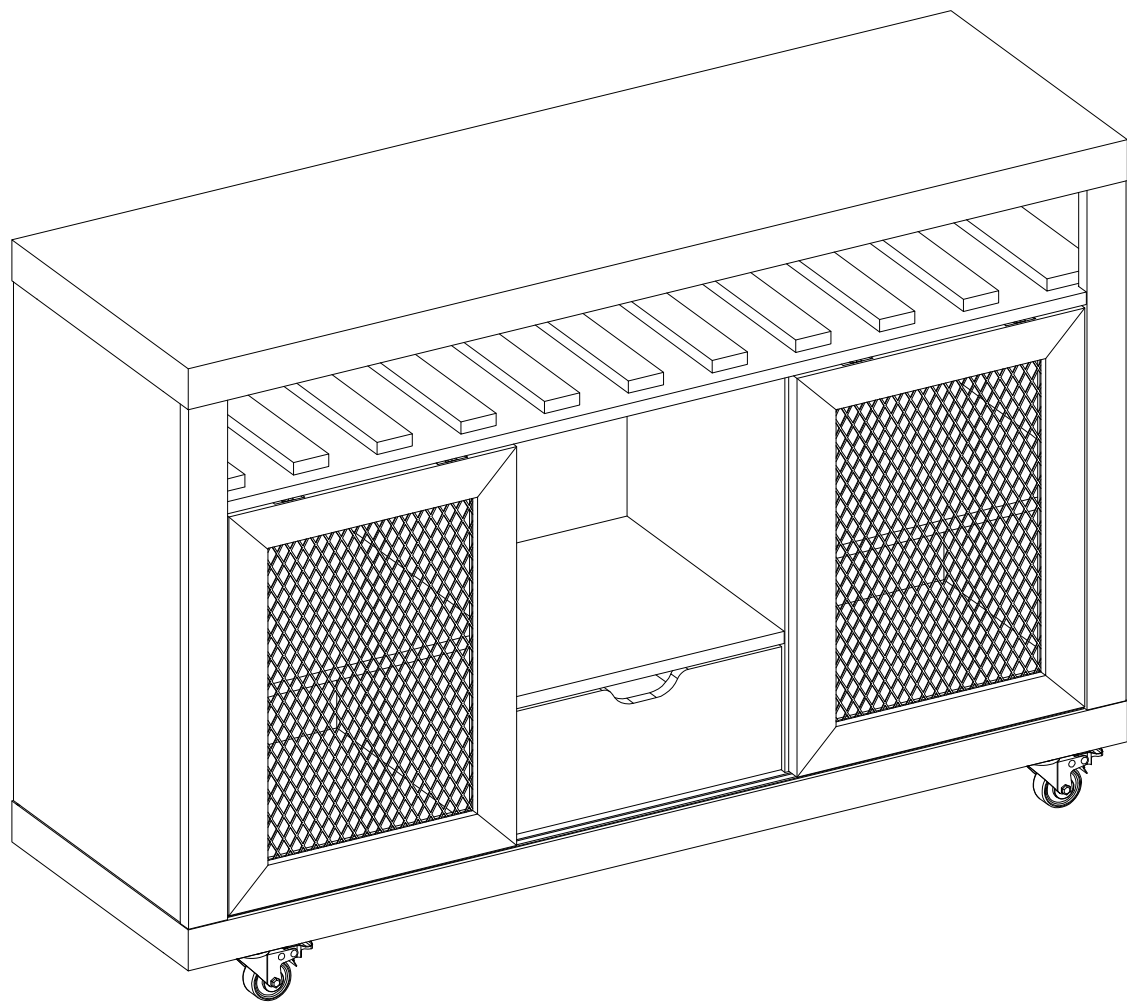

# GENERAL ASSEMBLY INSTRUCTIONS

**A few Tips before starting to assemble your new bookshelf, table, chair, or any other item**

- I. Before you can begin assembling your piece of furniture, make sure that there are no parts or hardware missing.
- II. Make sure you pay careful attention to each step before you progress onto the next step. This you will be able to assemble your item effectively and speedily.
- III. If you have help available, two people, or more are recommended to assist you to assemble the product. This ensures that it takes less time and less effort.
- IV. In the contents of the packaging, you will find pieces of Wood and individual dowels, screws, and bolts. These are the four main types of hardware that are required to assemble your item.
- V. Glue is included to ensure the wood dowels are secured effectively. Before you start inserting a dowel in place, make sure you find the right hole.
- VI. To insert securely, place a minimal amount of glue at the end of the dowel before you start attaching separate pieces of hardware.
- VII. A Philips head screw driver is a prerequisite to successfully assemble this product.
- VIII. Besides a power drill, power tools are not necessary to put this product together.
- IX. A drill may be needed to ensure that the product is efficiently secured to a wall.

**Some products may come with three-way hidden hinges.**

- a) These hidden three-way hinges can be fastened in place horizontally by mounting a screw.

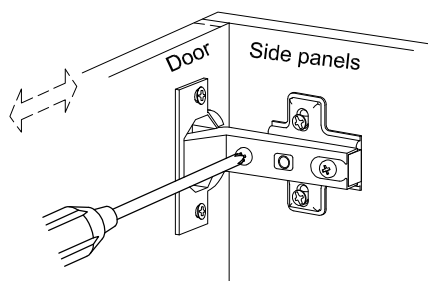

Horizontal  
by screw adjustment

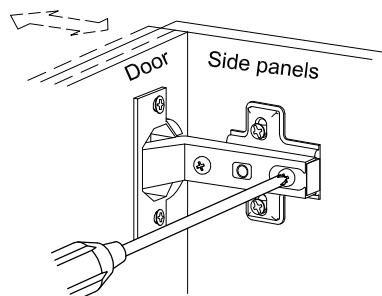

In-and-Out  
by loosening the hinge-arm  
mounting screw or via cam  
adjustment

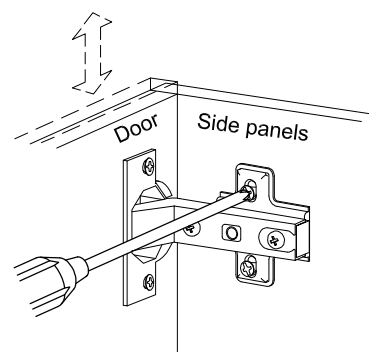

Vertical  
Via slots in the mounting  
plate or via cam adjustment

- b) They can be secured inward and outward by freeing the hinge arm, or vertically.
- c) This is done through gentle adjustment or slotting the hinges into the mounting plate.

# INSTRUCCIONES GENERALES PARA ENSAMBLE

Algunos consejos antes de comenzar a armar su nueva estantería, mesa, silla o cualquier otro artículo

- I. Antes de que pueda comenzar a ensamblar su mueble, asegúrese de que no falten piezas o hardware.
- II. Asegúrese de prestar mucha atención a cada paso antes de avanzar al siguiente paso. De esta manera, podrá ensamblar su artículo de manera efectiva y rápida.
- III. Si tiene ayuda disponible, se recomiendan dos personas o más para ayudarlo a ensamblar el producto. Esto asegura que tome menos tiempo y menos esfuerzo.
- IV. En el contenido del embalaje, encontrará piezas de madera y clavijas, tornillos y pernos (Tarugos) individuales. Estos son los cuatro tipos principales herramientas que se requieren para ensamblar su artículo.
- V. Se incluye pegamento para garantizar que las clavijas de madera se aseguren de manera efectiva. Antes de comenzar a insertar una clavija en su lugar, asegúrese de encontrar el orificio correcto.
- VI. Para insertar de forma segura, coloque una cantidad mínima de pegamento al final de la clavija antes de comenzar a colocar piezas separadas de hardware.
- VII. Un destornillador de cabeza Philips (Tornillos de tria ) es un requisito previo para ensamblar con éxito este producto.
- VIII. Además de un taladro eléctrico, no son necesarias herramientas eléctricas para armar este producto.
- IX. Es posible que se necesite un taladro para garantizar que el producto se asegure de manera eficiente a una pared.

**Algunos productos pueden venir con bisagras ocultas de tres vías.**

- a) Estas bisagras ocultas de tres vías se pueden sujetar en su lugar horizontalmente montando un tornillo.

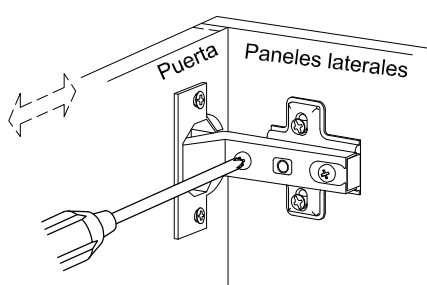

Horizontal  
mediante el ajuste del tornillo

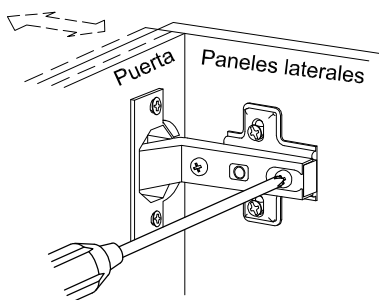

Hacia adentro o afuera  
al aflojar el brazo de la bisagra  
tornillo de montaje o mediante  
ajuste de la leva

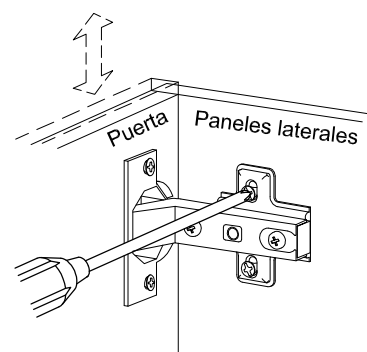







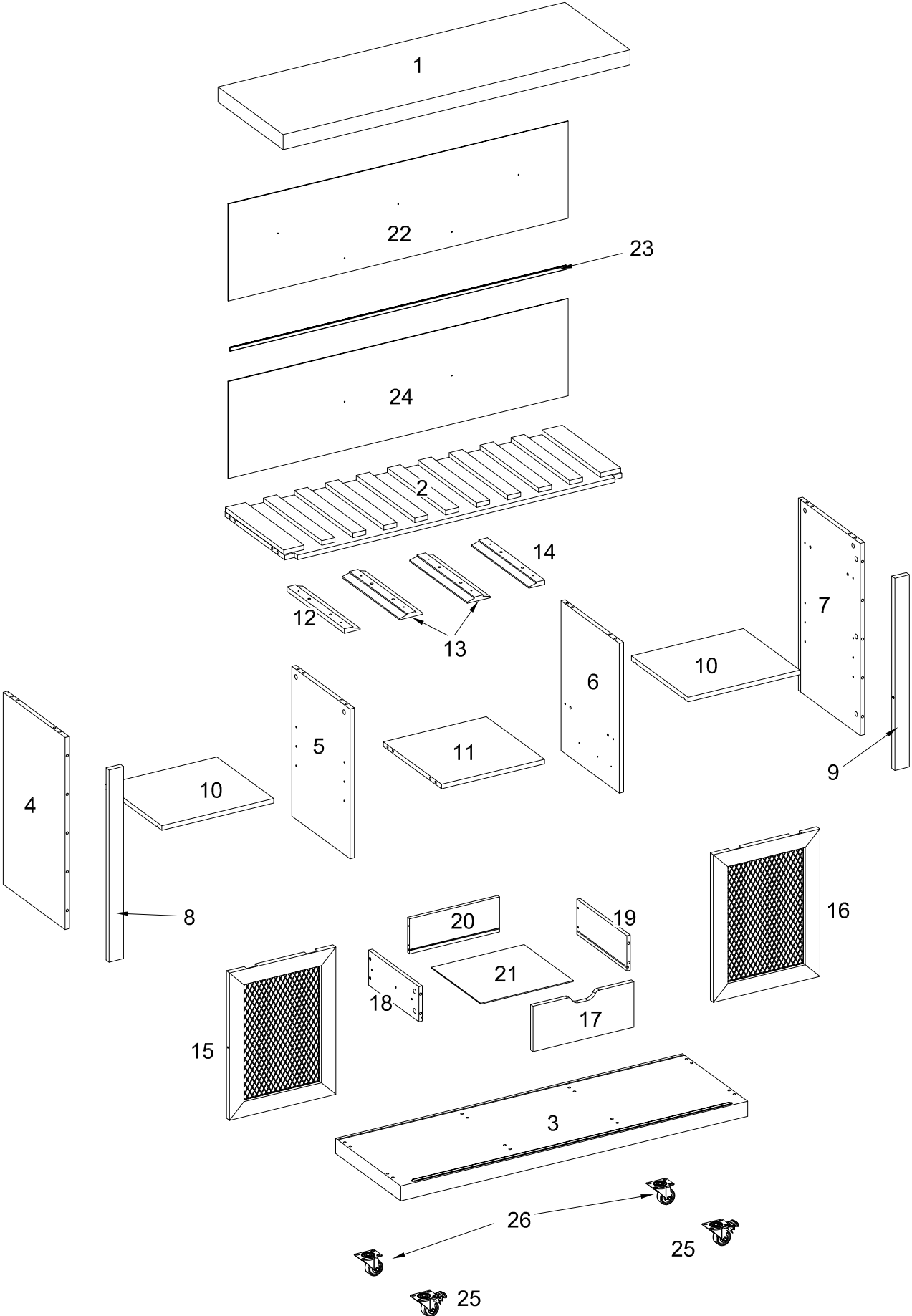





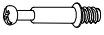



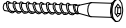



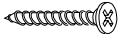

Vertical  
por medio de ranuras en la  
placa de montaje o mediante  
el ajuste de la leva

- b) Se pueden asegurar hacia adentro y hacia afuera liberando el brazo de la bisagra, o verticalmente:
- c) Esto se hace a través de un ajuste suave o ranurando las bisagras en la placa de montaje.

# Parts List



# Hardware List

A		Ø8x30mm	Wood dowel	28 pcs
B		Ø8x20mm	Wooden dowel	8 pcs
C		Ø6x35mm	Cam bolt	26 pcs
D		Ø15x11mm	Cam lock	22 pcs
E		Ø15x9mm	Small Cam lock	4 pcs
F			Side panel sticker	10 pcs
G			Others panel sticker	16 pcs
H		Ø6x50mm	Screw	8 pcs
I		Ø6x12mm	Bolt	16 pcs
J			Plastic wedge	10 pcs
K		Ø3x17mm	Flat-head screw	10 pcs
L		Ø4x32mm	Screw	4 pcs
M		Ø4x25mm	Screw	8 pcs
N			Glue	1 pcs
O			Pulley	4 pcs
P			Pulley	4 pcs
Q		12"	Drawer slider	1 set
R		Ø3x12mm	Screw	44 pcs
S		Ø5x16mm	Shelf support pin	8 pcs
T		Ø5x8mm	Metal place	2 pcs
U		M 4	Hexagon socket key	1 pcs
V		Ø3x12mm	Screw	7 pcs
W			Tipping Restraint Hardware (Inside Plastic White Bag)	2 set

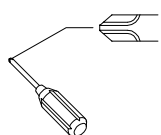

Philips head screwdriver required for assembly  
(not included)

# Step 1

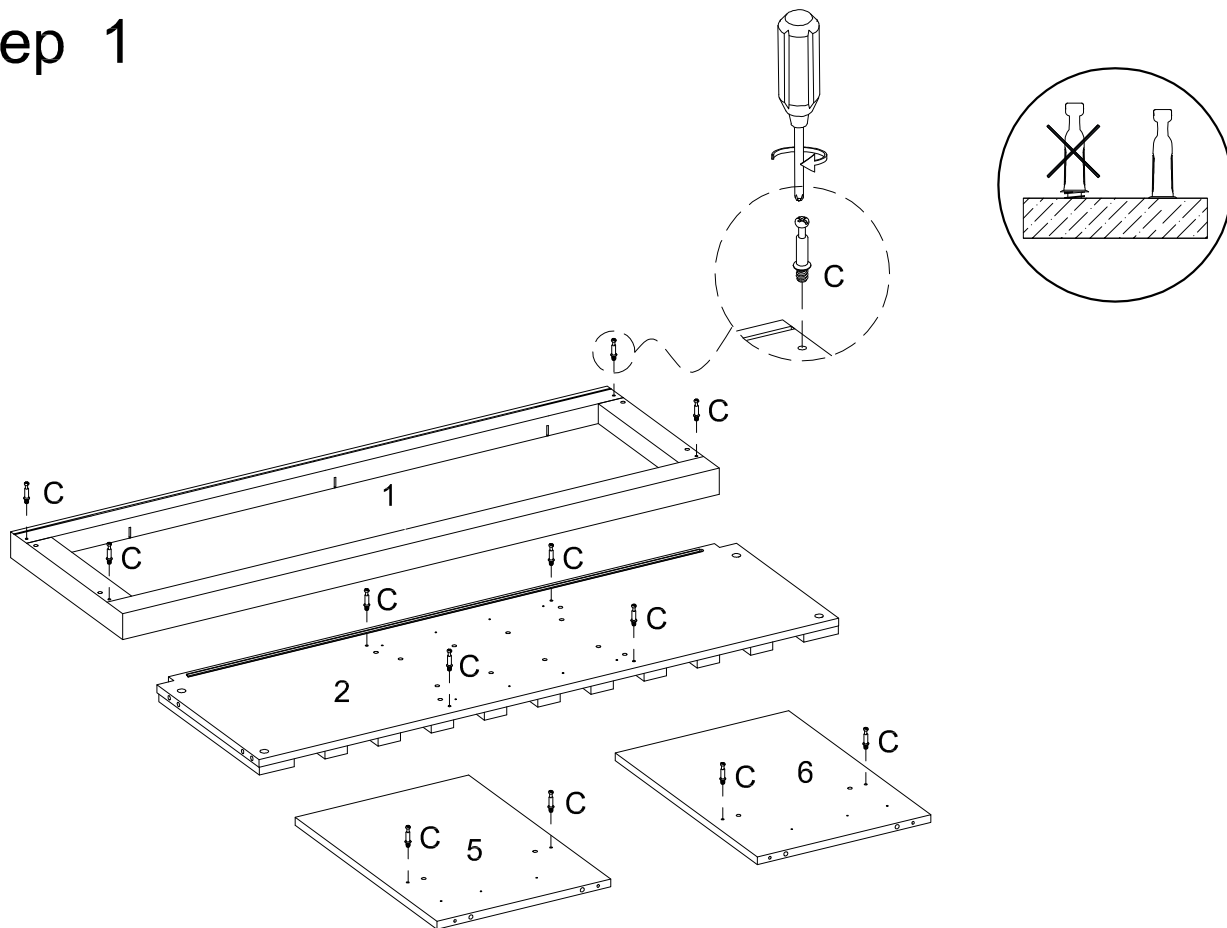

# Step 2

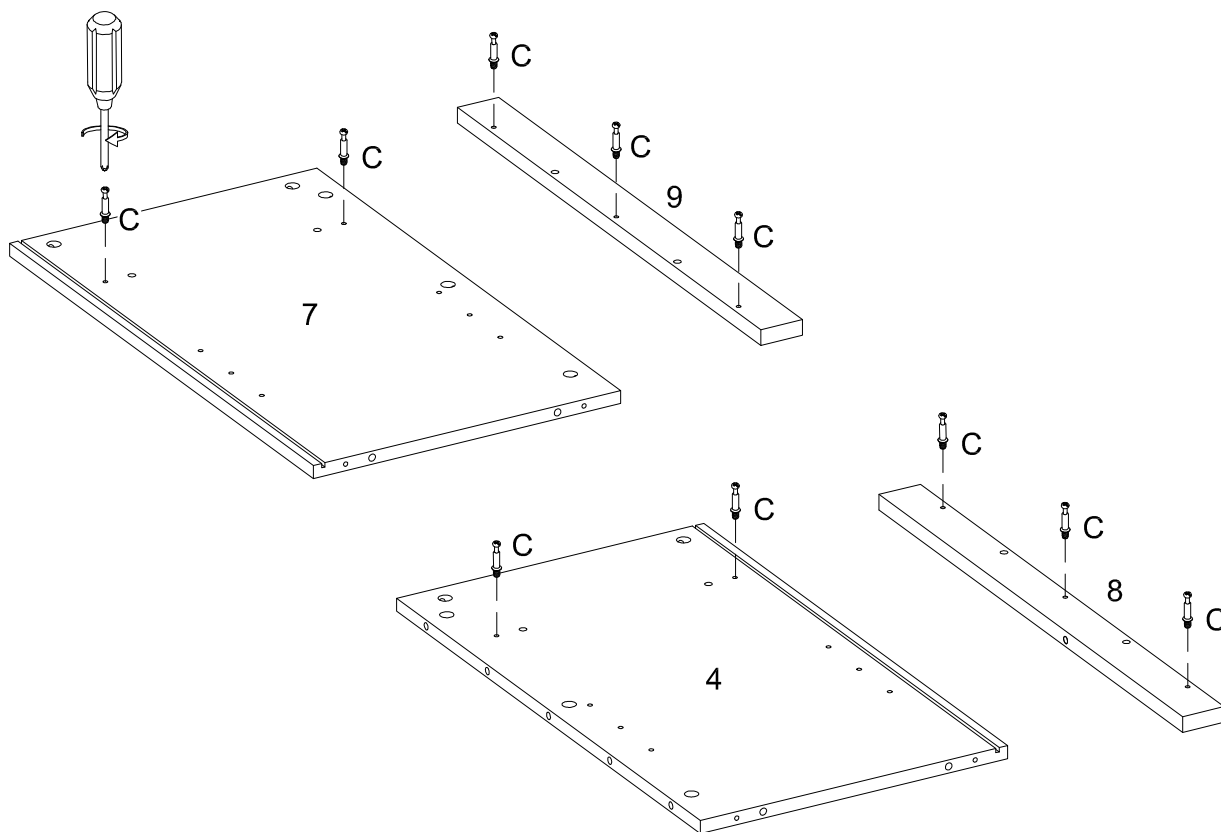

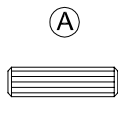
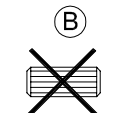
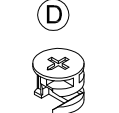
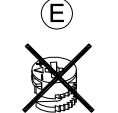

# Step 3

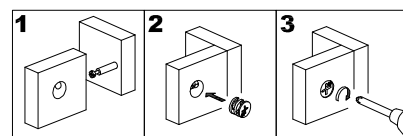
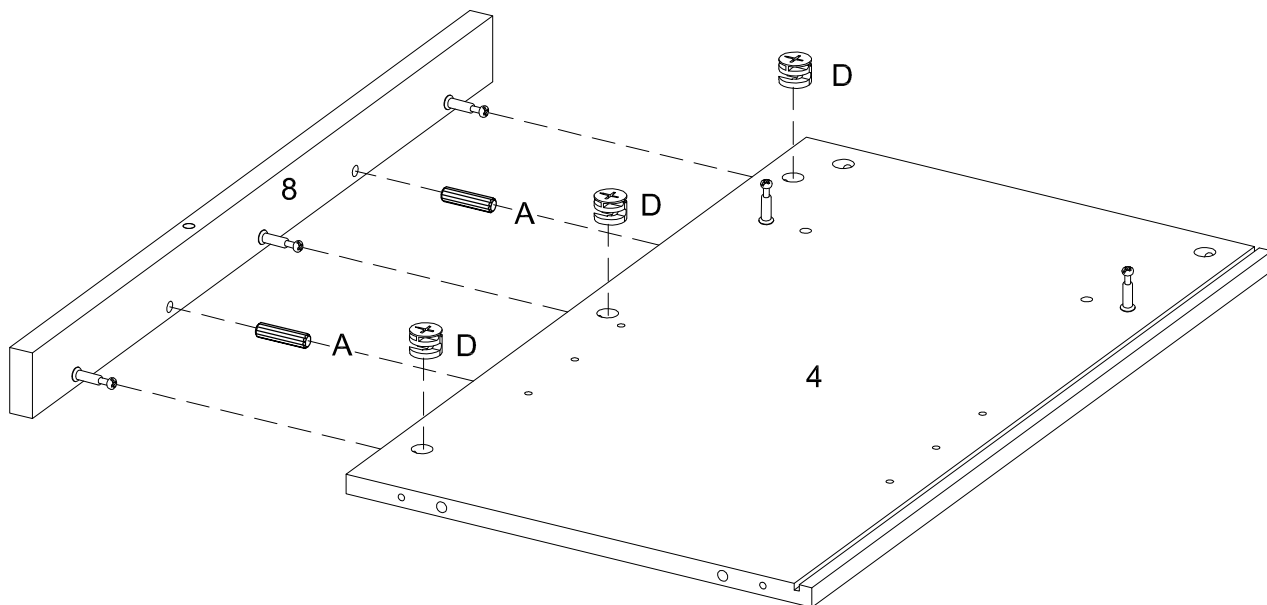
<b>(A)</b>  Ø8x30mm	<b>(B)</b>  Ø8x20mm	<b>(D)</b>  Ø15x11mm	<b>(E)</b>  Ø15x9mm
--	---	---	--

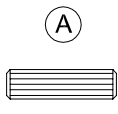
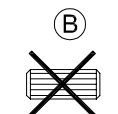

# Step 4

<b>(A)</b>  Ø8x30mm	<b>(B)</b>  Ø8x20mm	<b>(D)</b>  Ø15x11mm	<b>(E)</b>  Ø15x9mm
--	--	---	--

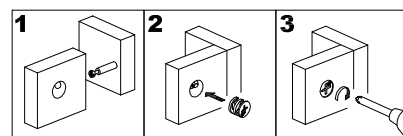
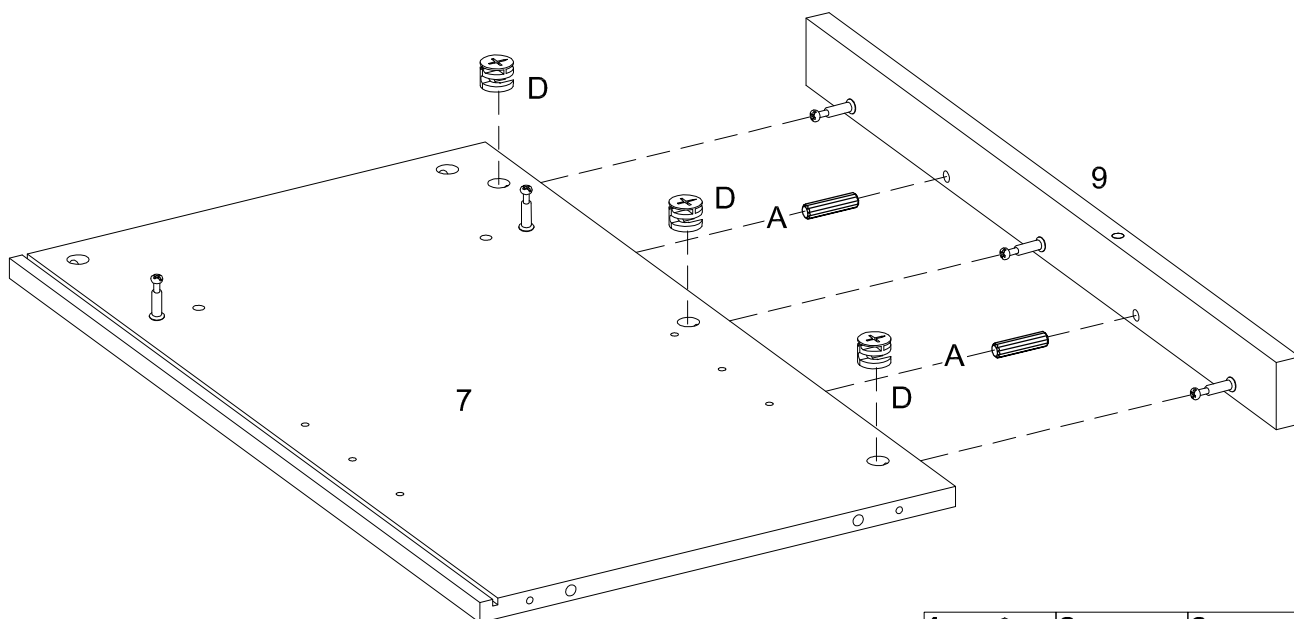

## Step 5

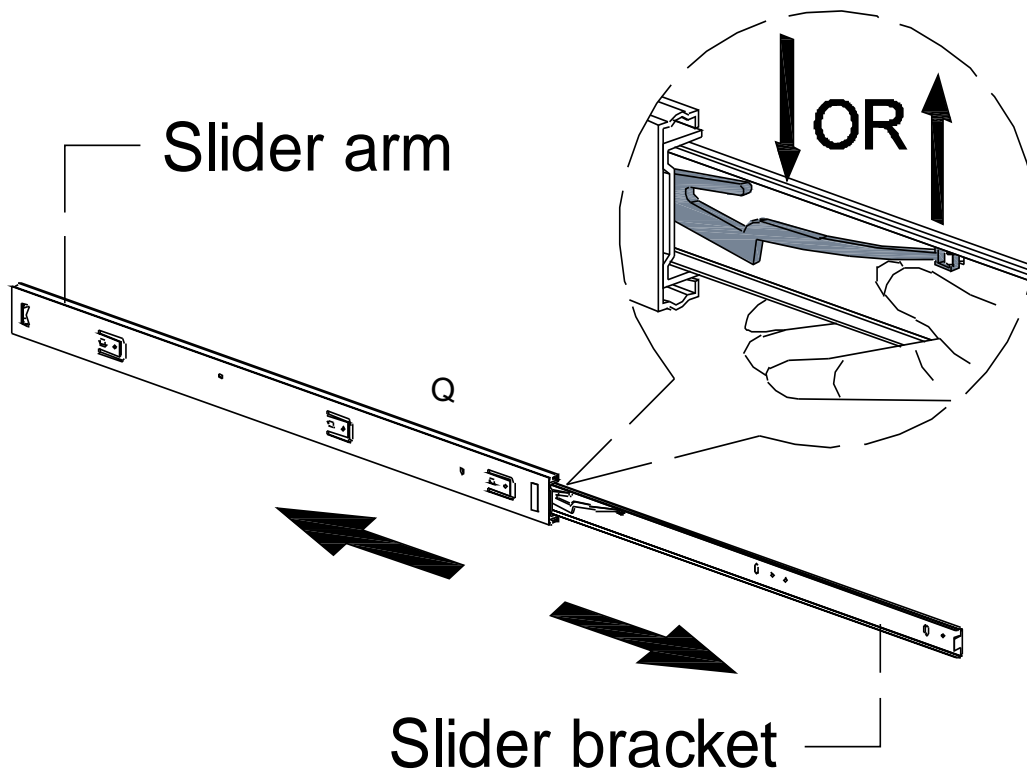

## Step 6

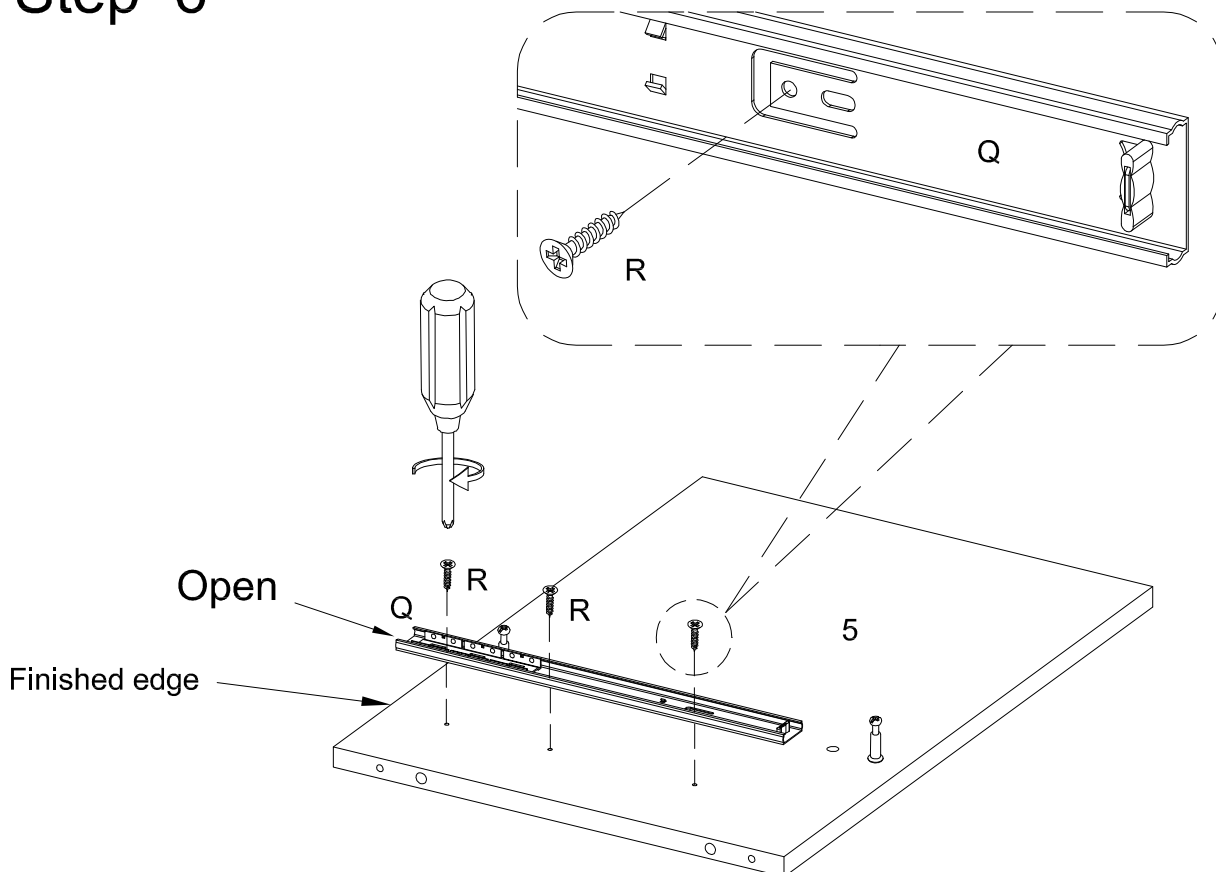



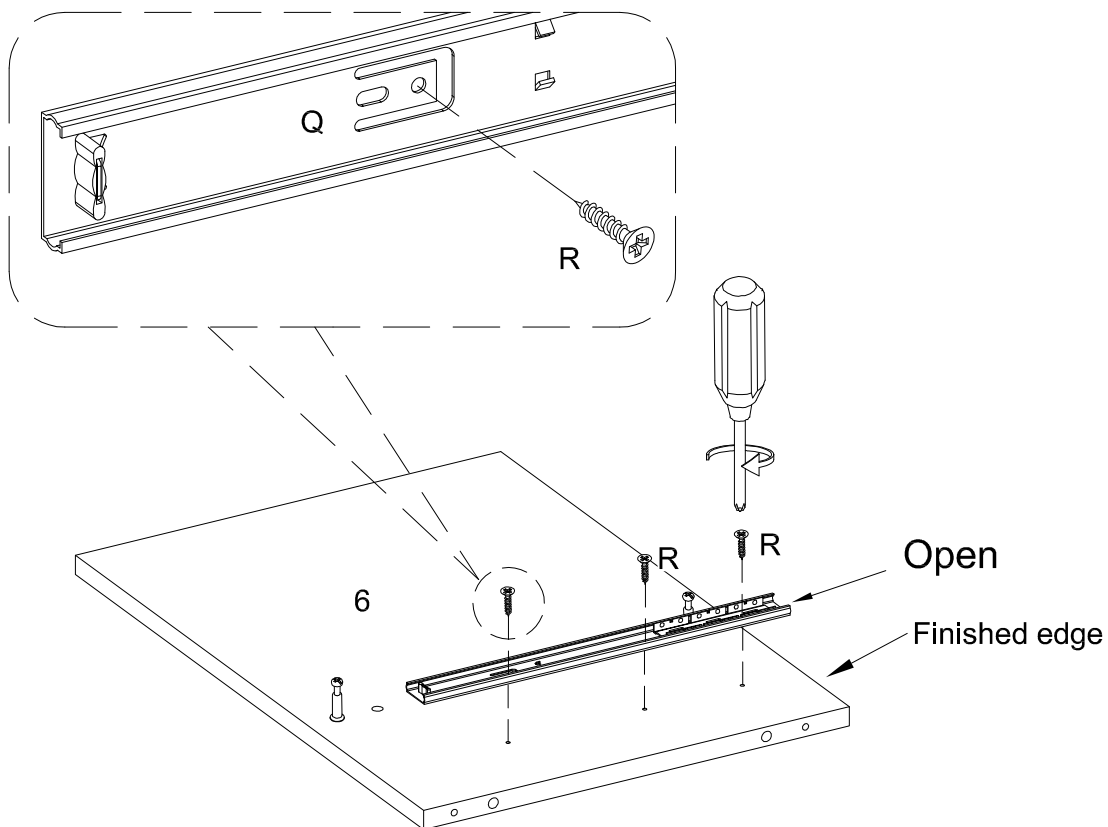

# Step 7

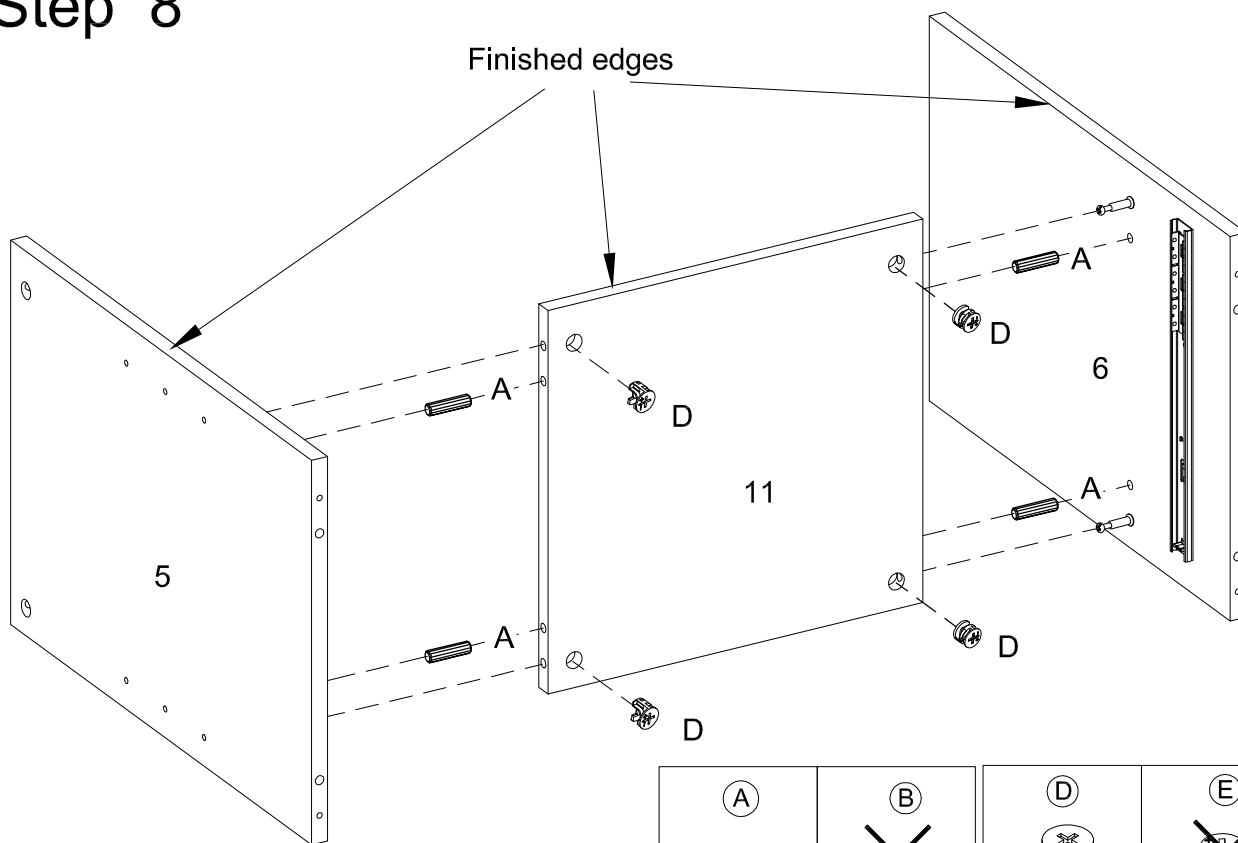

# Step 8

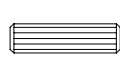
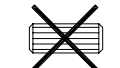

<p>(A)</p>  <p>Ø8x30mm</p>	<p>(B)</p>  <p>Ø8x20mm</p>	<p>(D)</p>  <p>Ø15x11mm</p>	<p>(E)</p>  <p>Ø15x9mm</p>
---	---	--	---

# Step 9

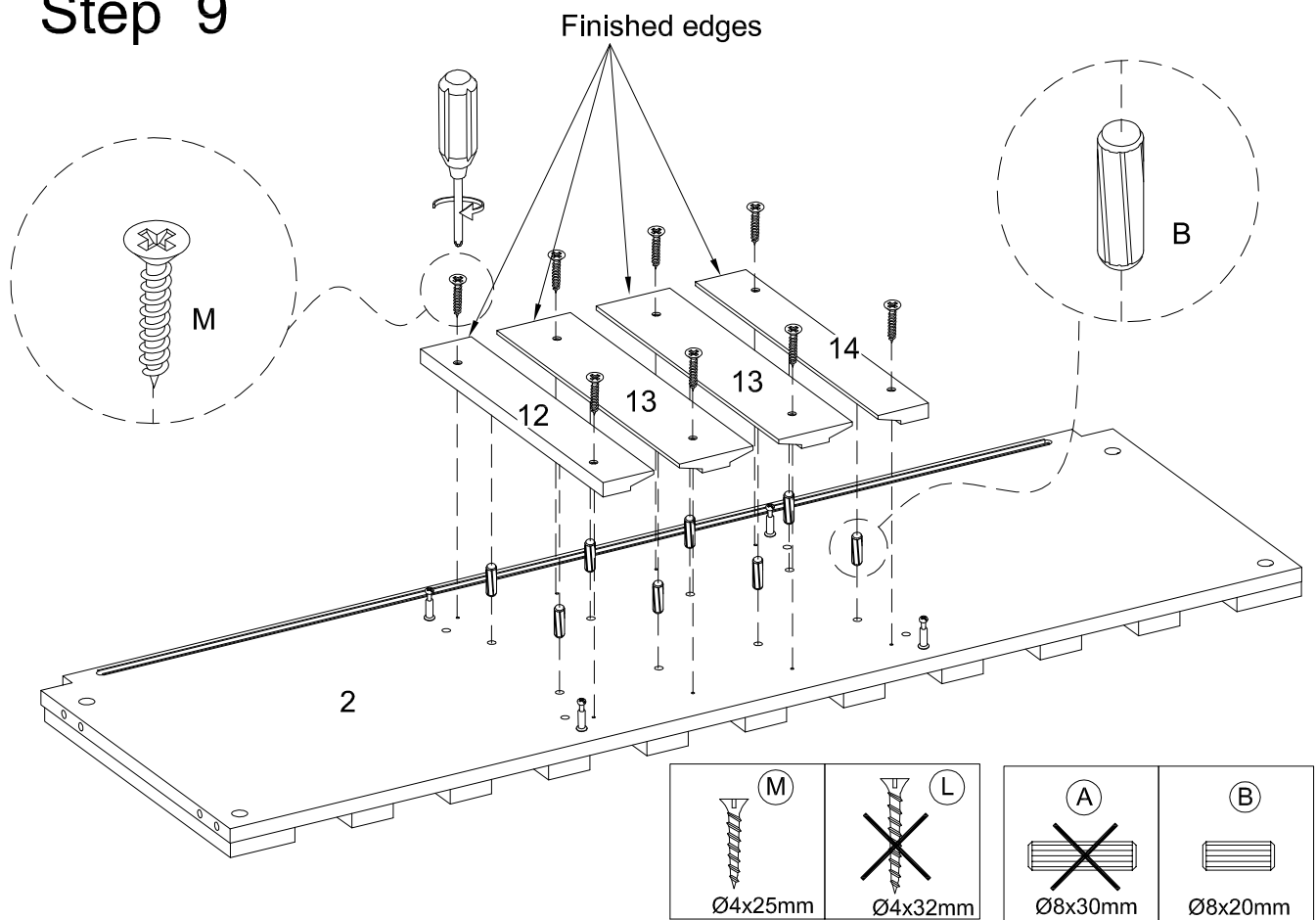

# Step 10

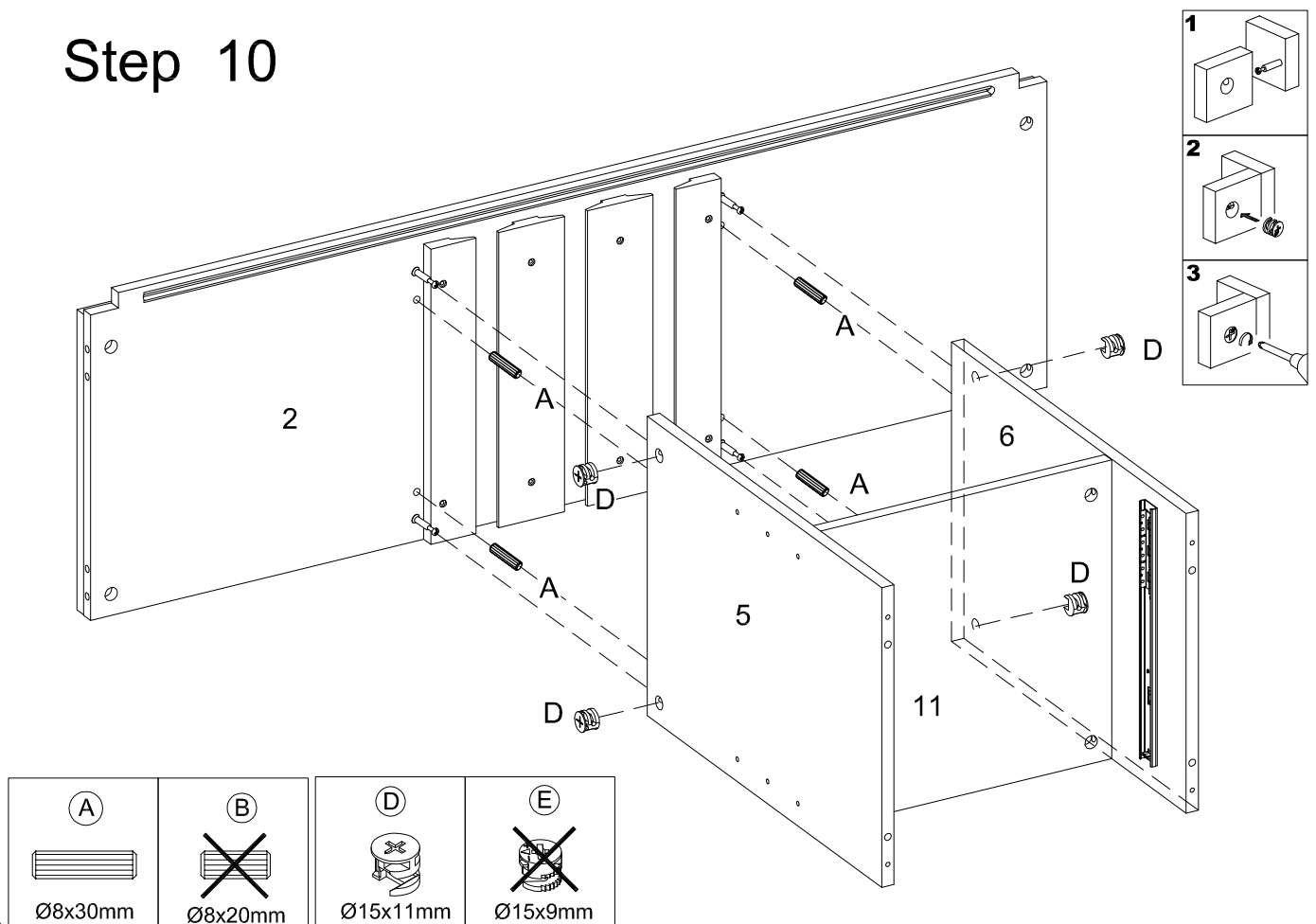

# Step 11

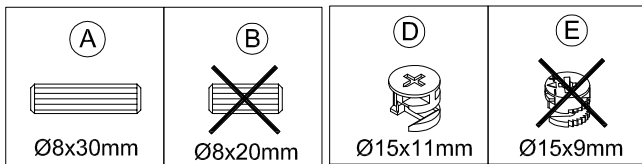
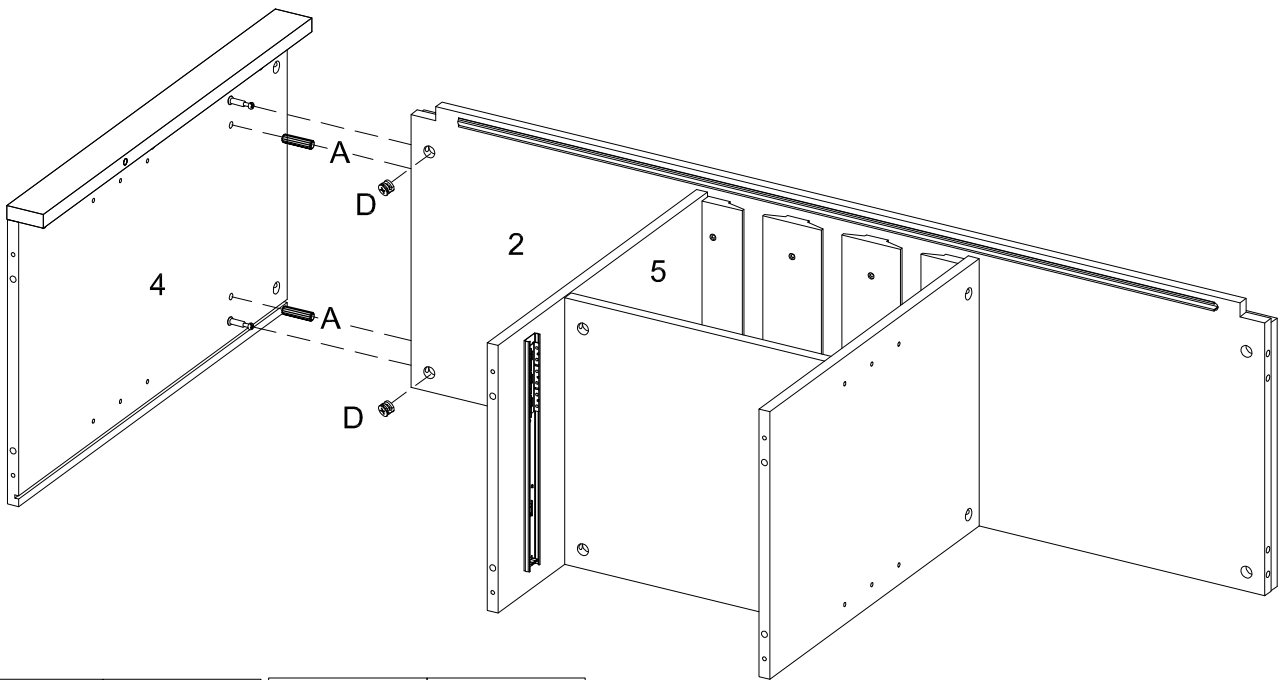
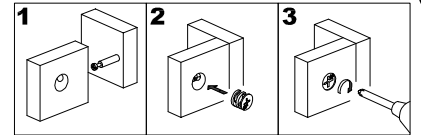

# Step 12

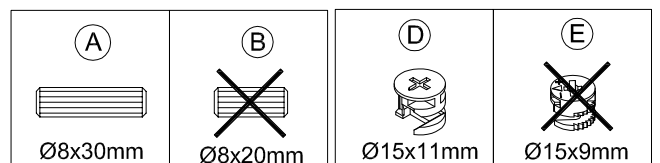
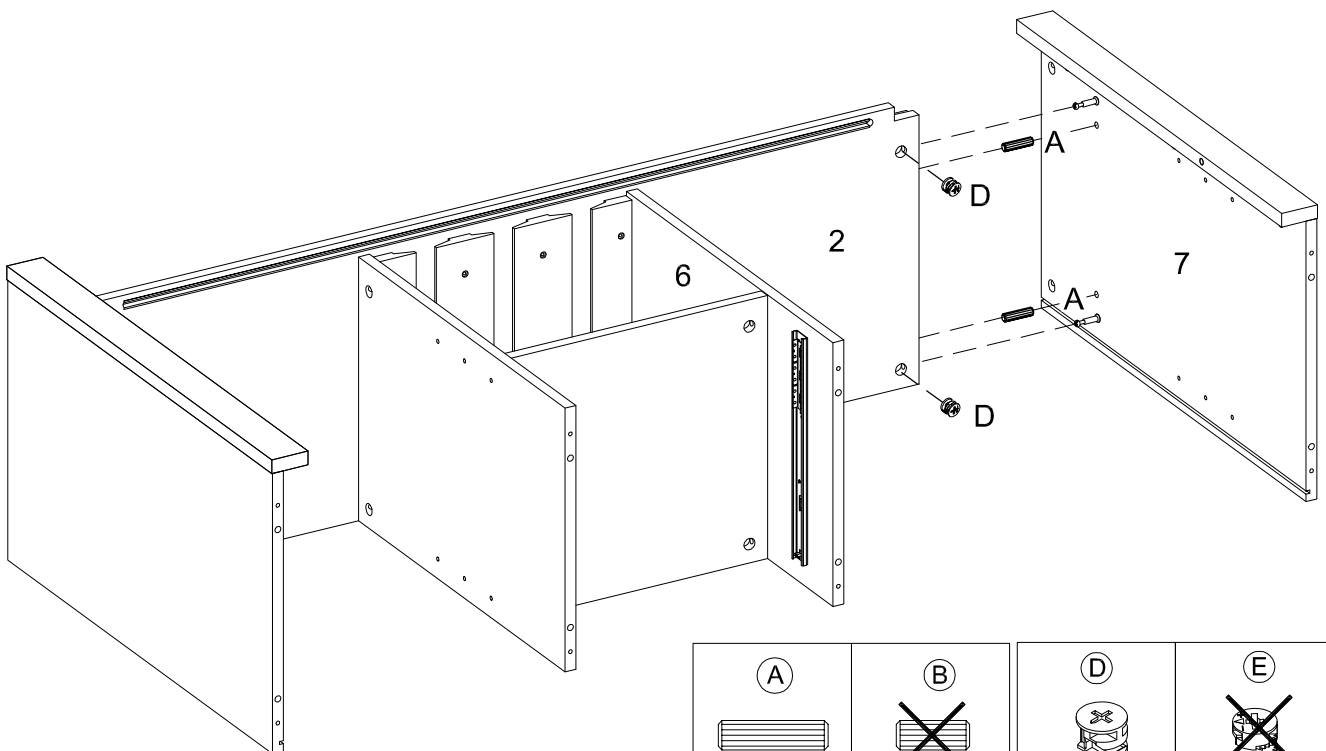
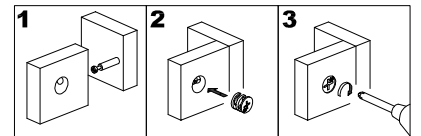



# Step 15

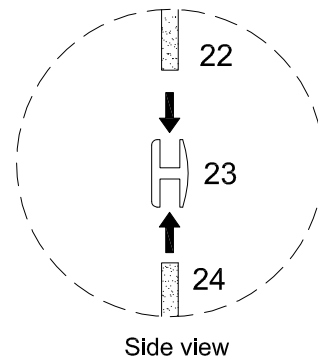
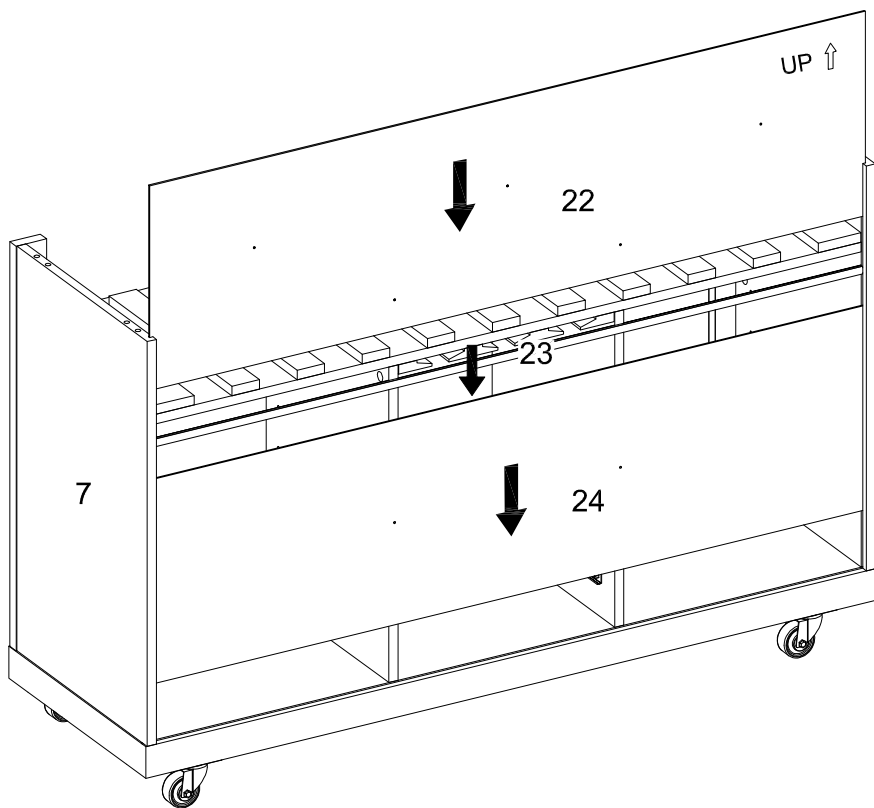

# Step 16

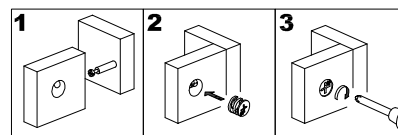
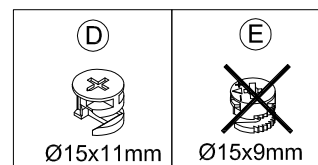
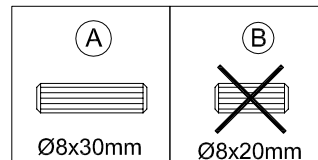
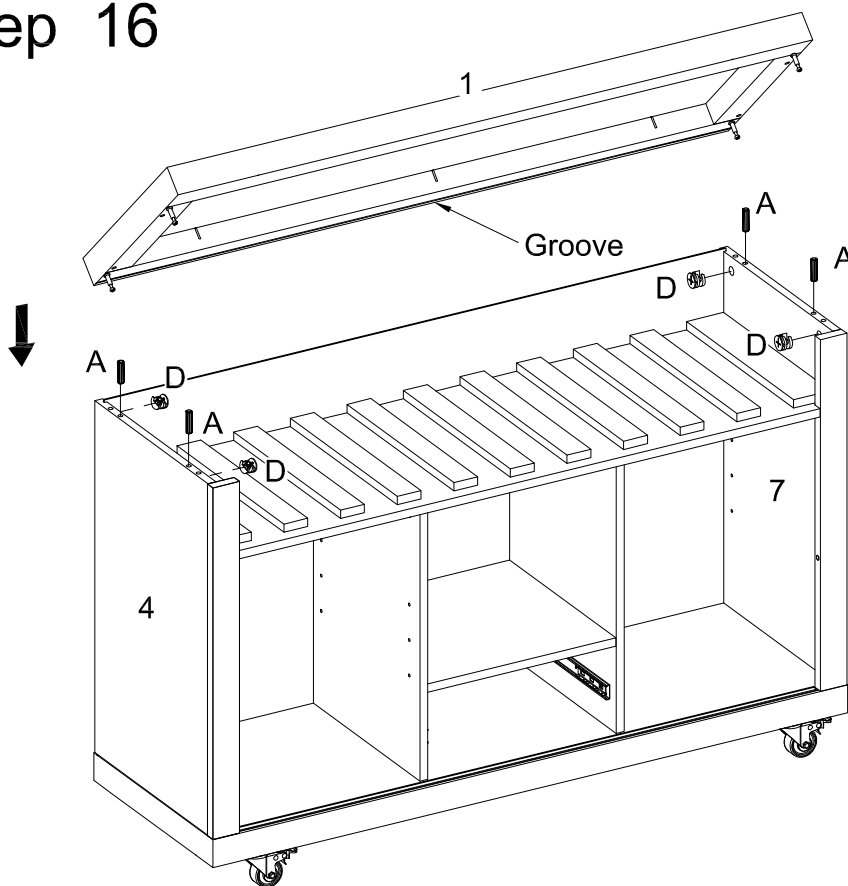

# Step 17

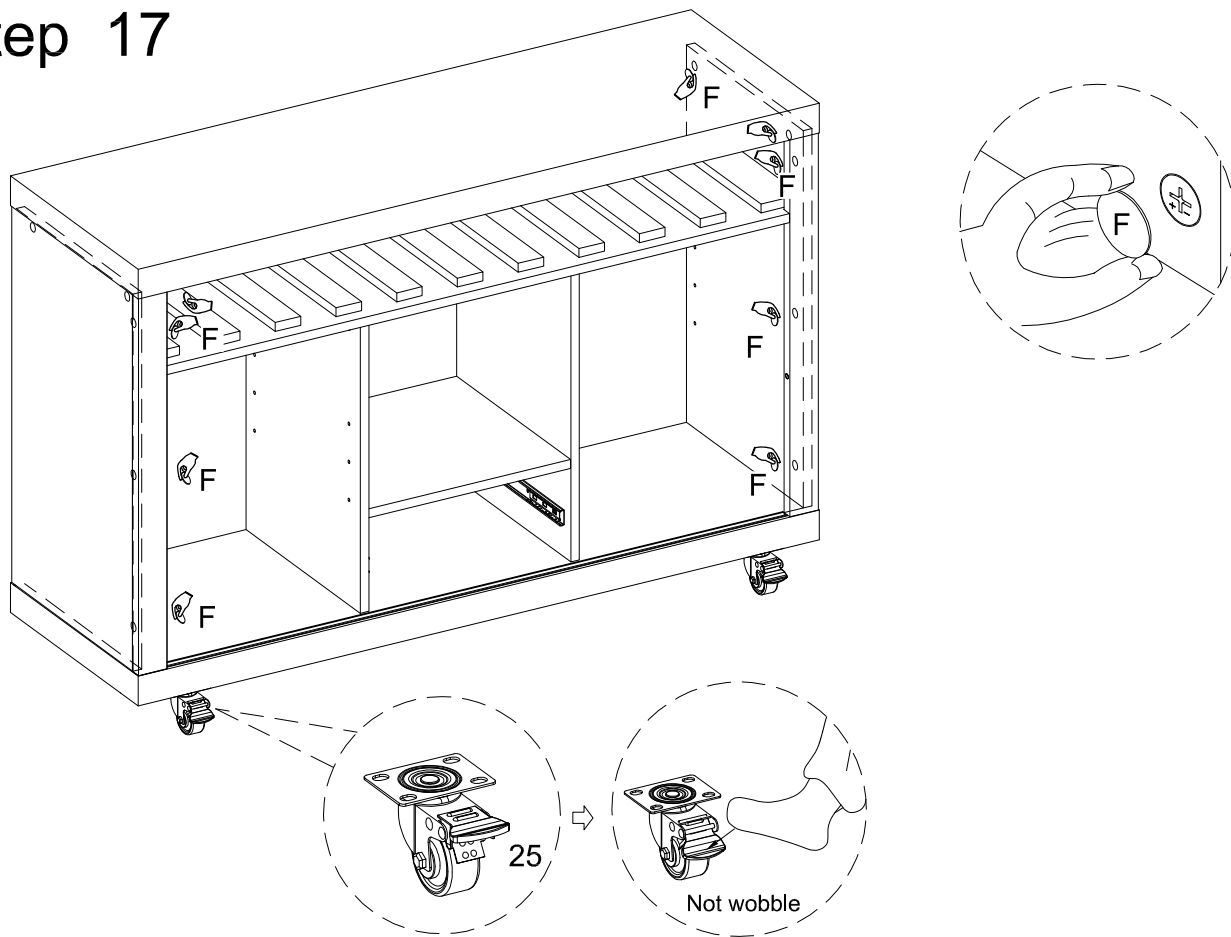

# Step 18

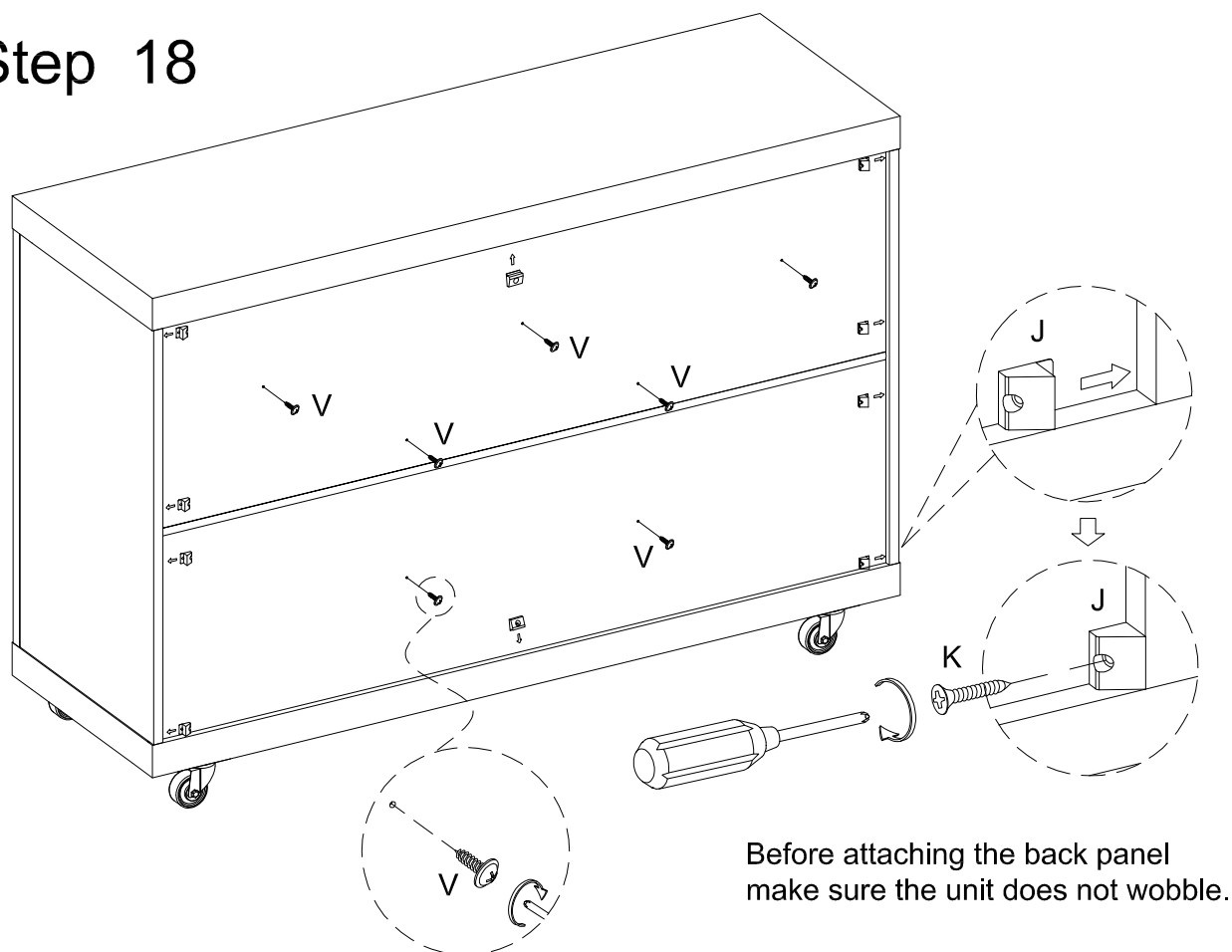

# Step 19

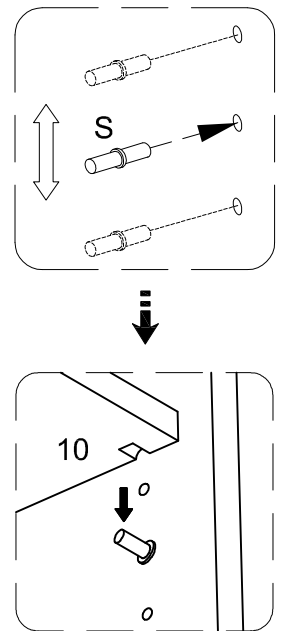
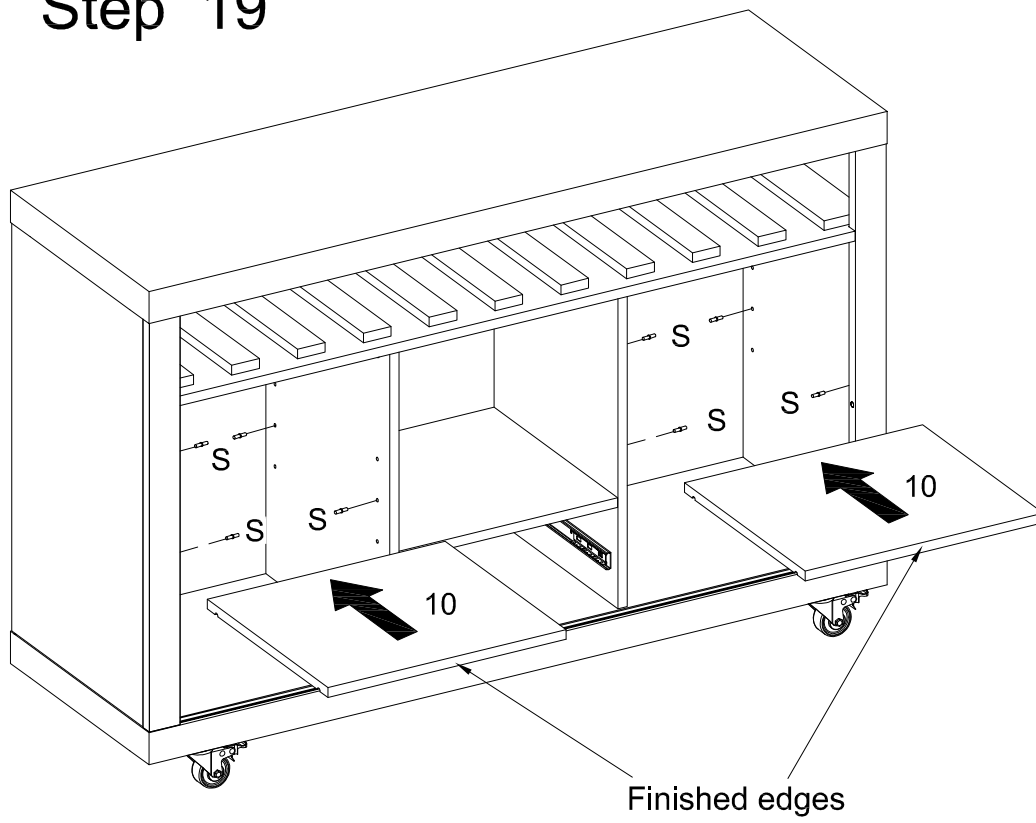

# Step 20

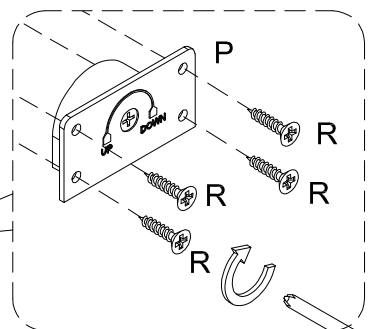
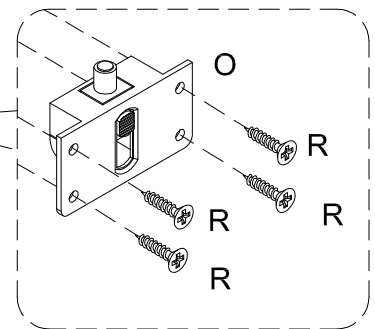
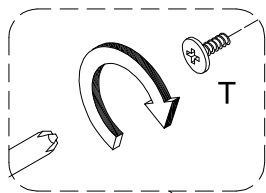
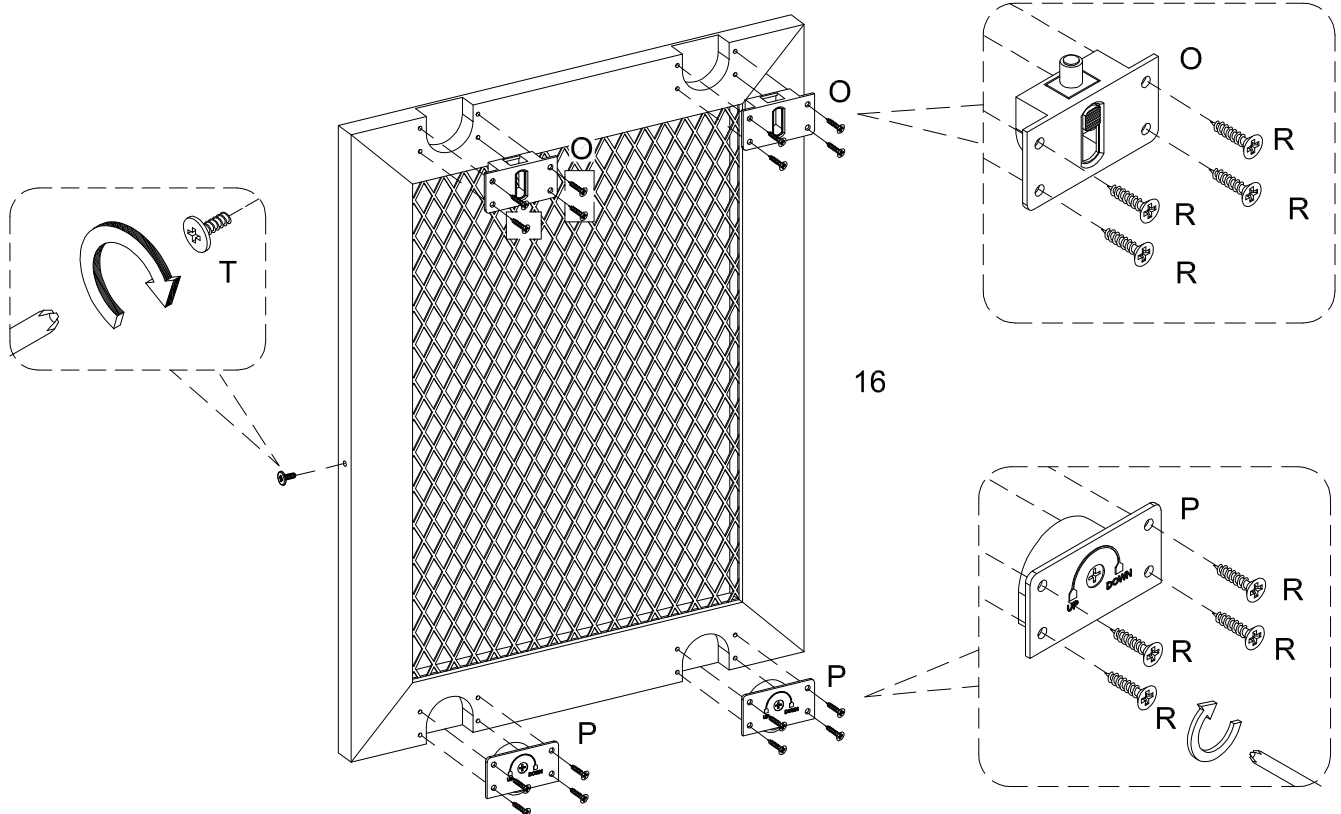

# Step 21

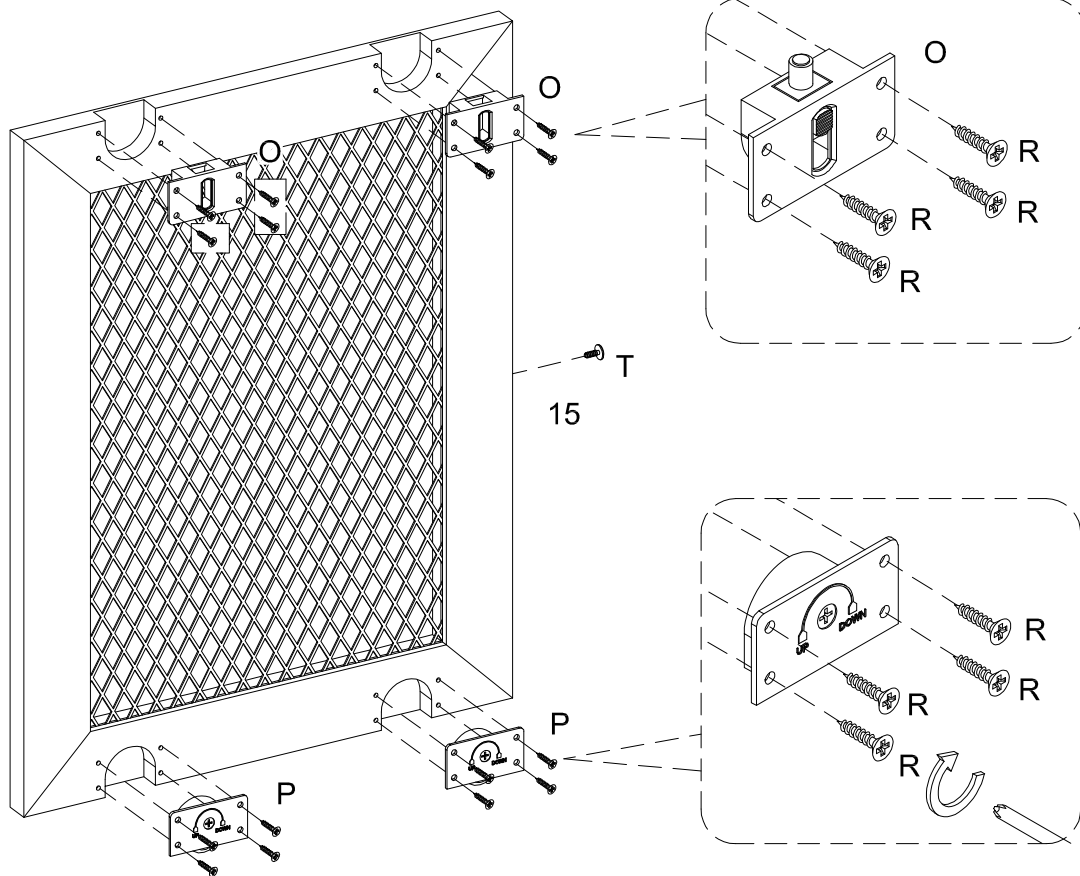

# Step 22

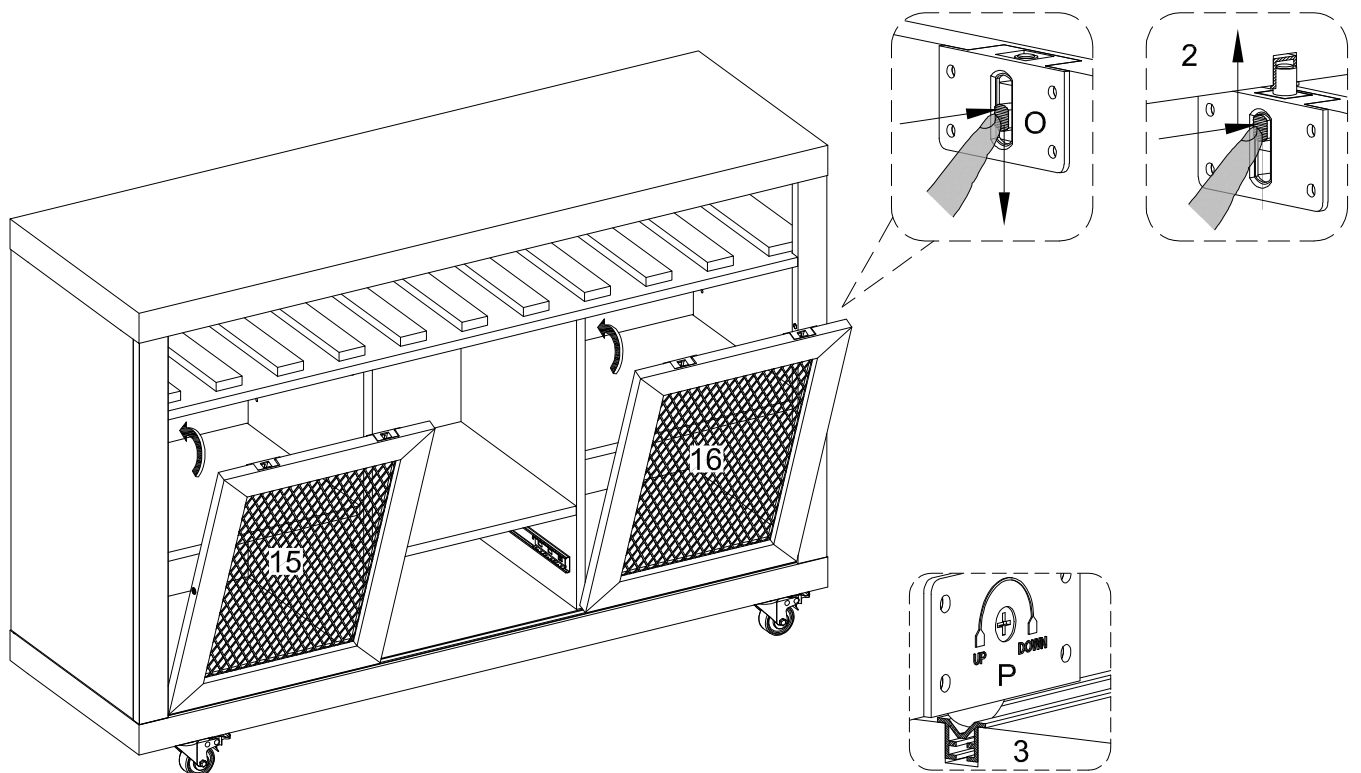



# Step 23

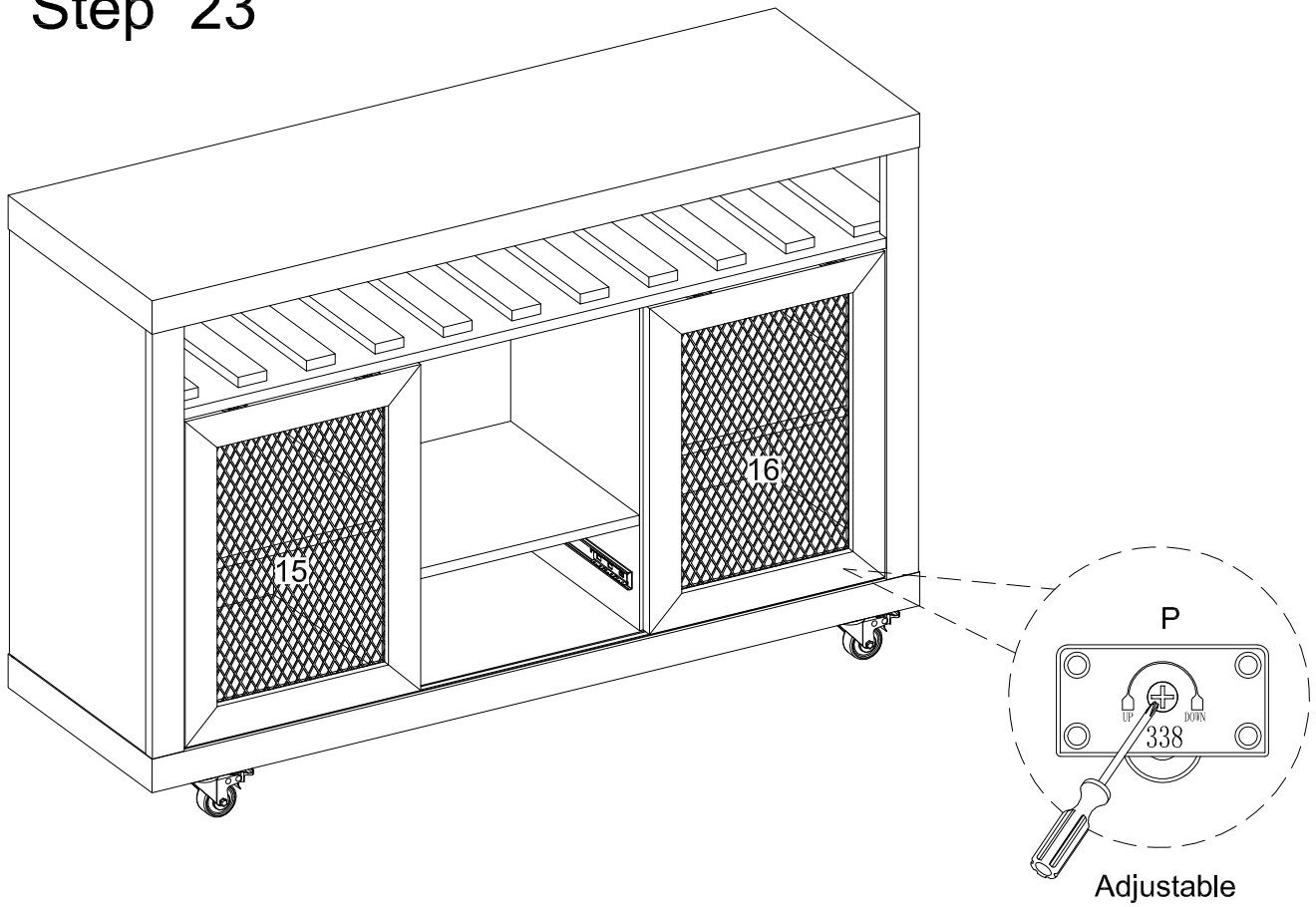

# Step 24

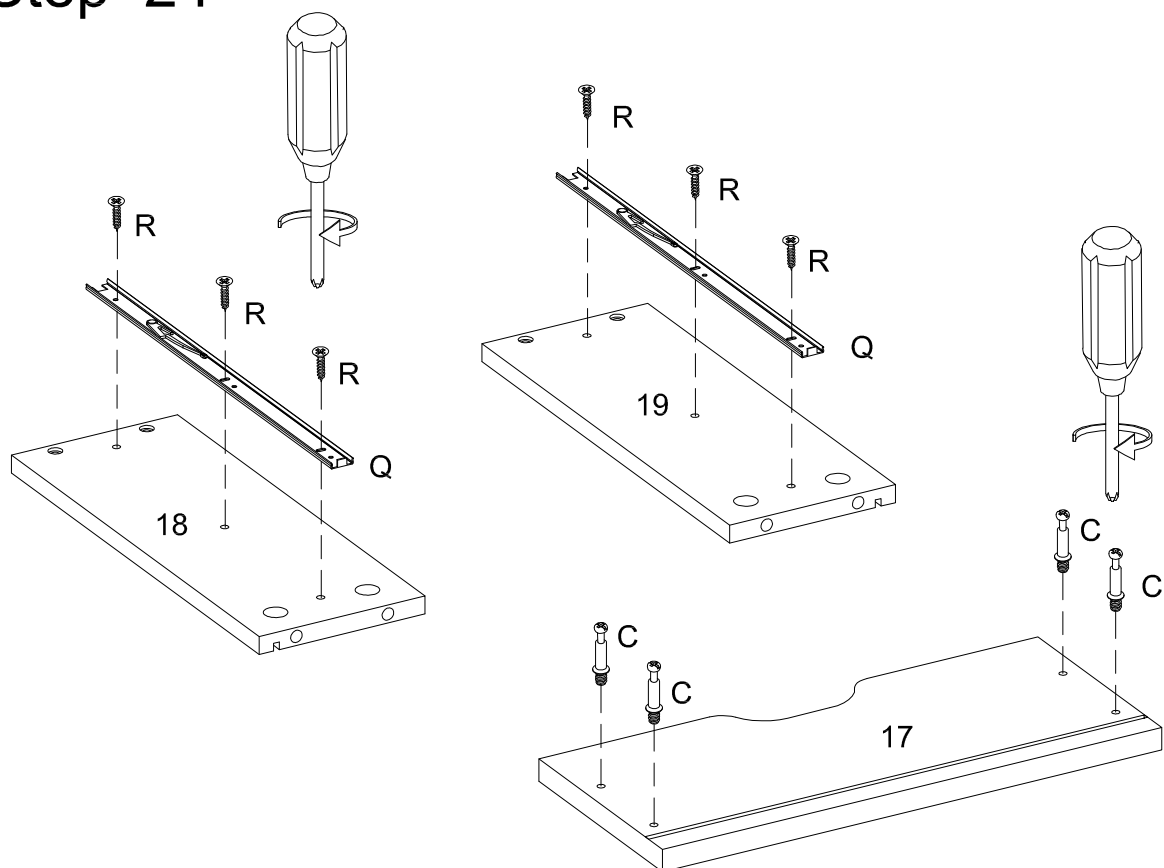

# Step 25

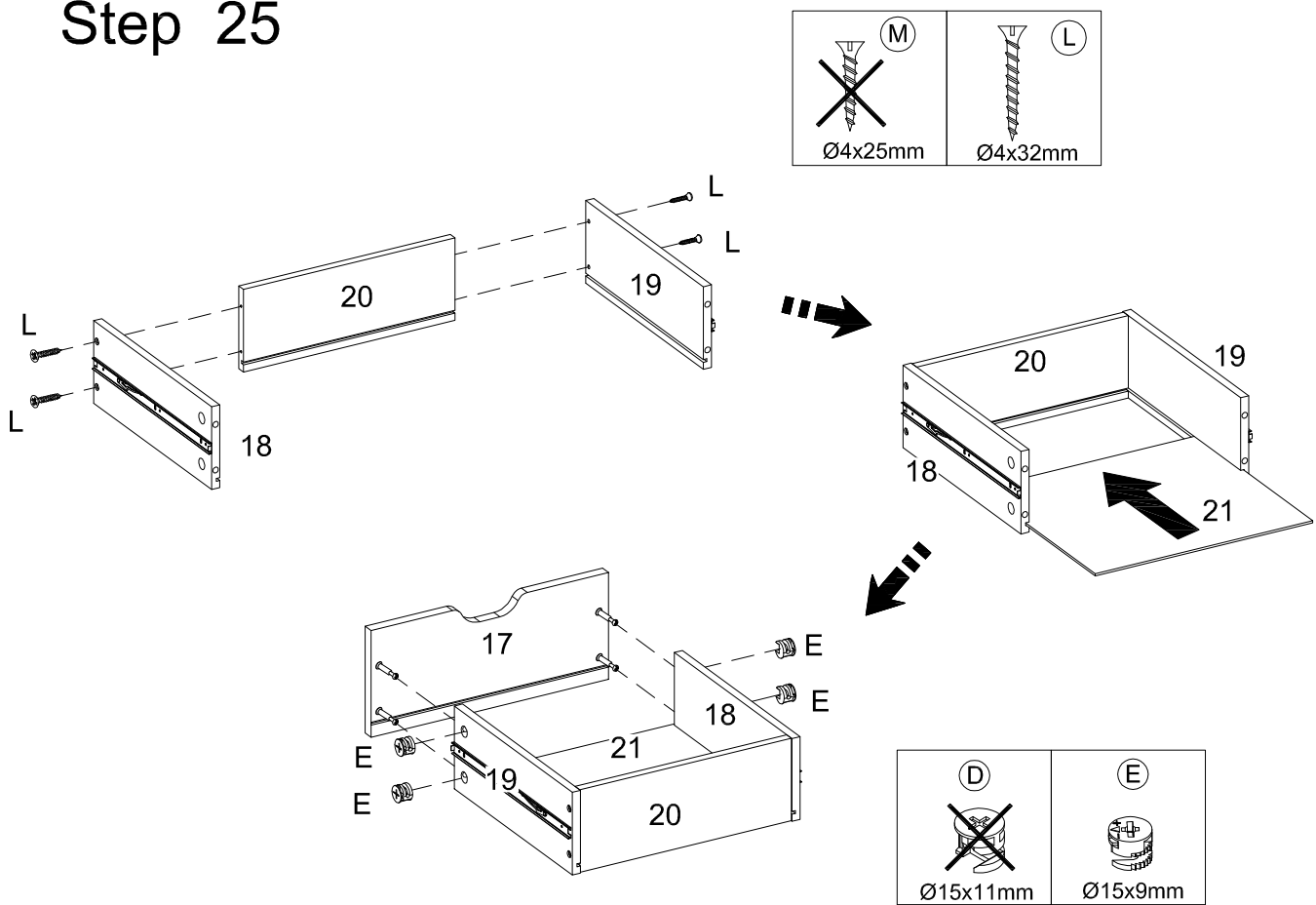

# Step 26

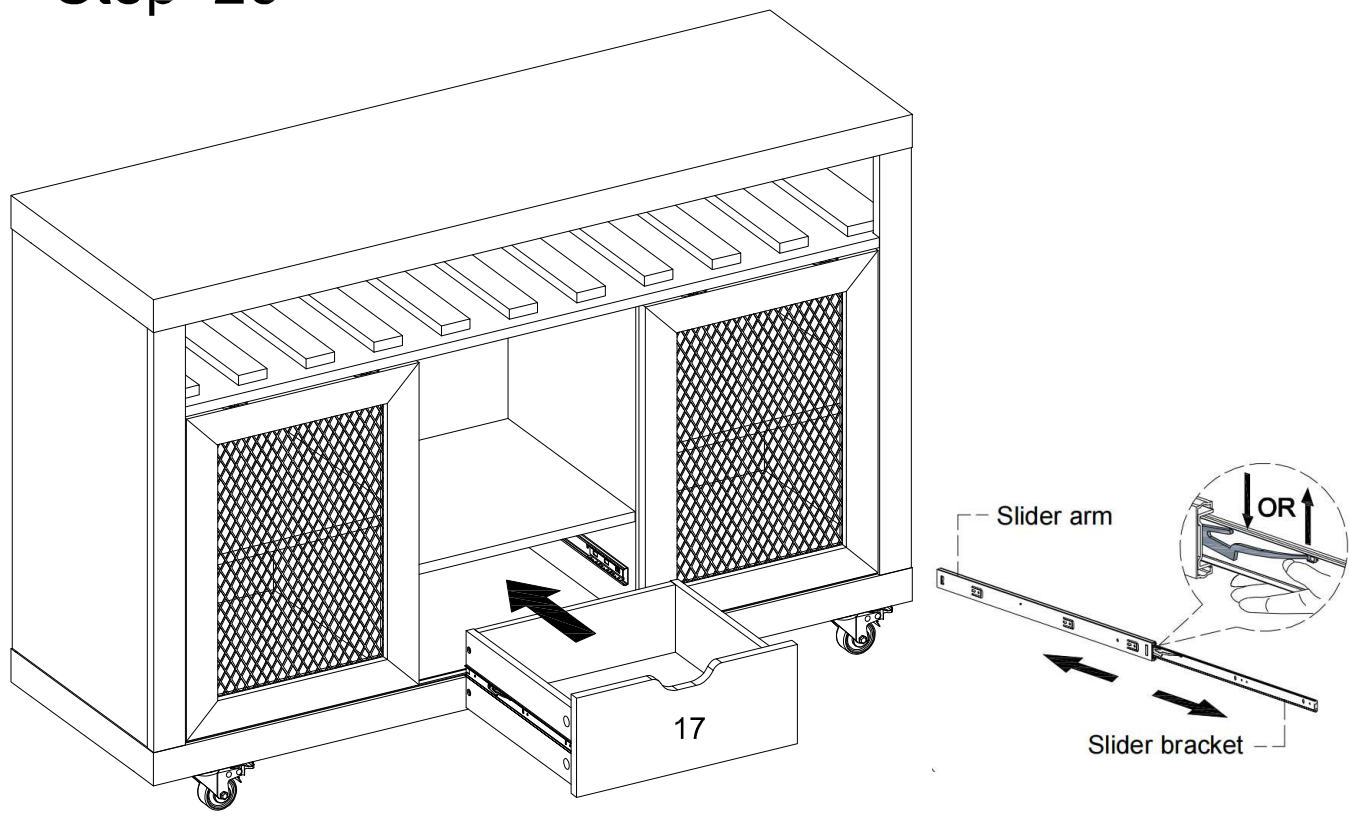

# Step 27

## WARNING

You must install the tip restraint hardware to help prevent any accidents or damage to the unit. We strongly recommend attaching the tip restraint hardware to a wall stud and your unit. For all other wall types, please visit your local hardware store to obtain the proper hardware.



Short Screw

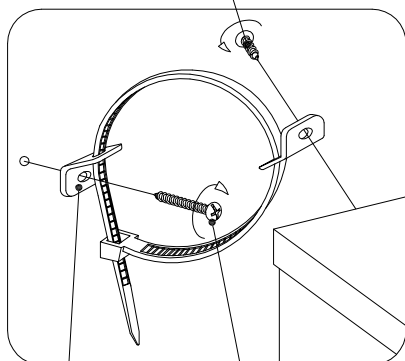

Metal Bracket

Long Screw

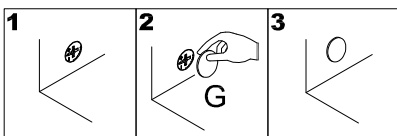
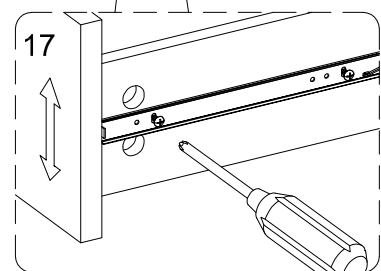
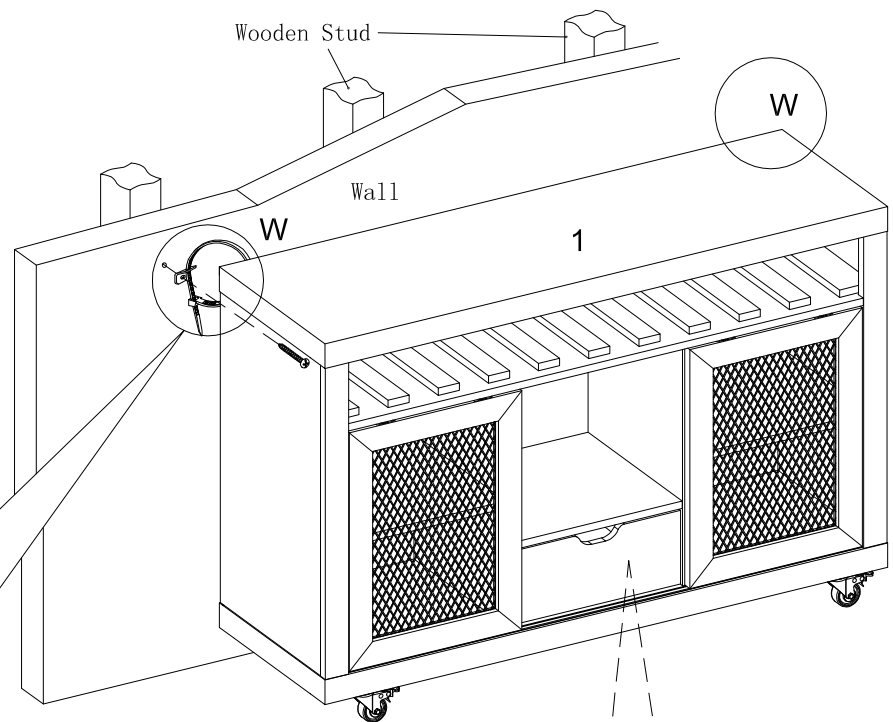

Finally